



# FPA-320x256-K-TE2 InGaAs Imager

## NEAR INFRARED ( 0.9 $\mu\text{m}$ - 1.7 $\mu\text{m}$ ) IMAGE SENSOR

### FEATURES

- 320x256 Array Format
- 28-pin Metal DIP Package
- Embedded 2-stage Thermoelectric Cooler
- Typical Pixel Operability >99.5%
- Quantum Efficiency >70%

### APPLICATIONS

- Near-infrared Imaging
- Imaging Spectroscopy
- Covert Surveillance
- Nondestructive Inspection
- Medical Science and Biology
- Astronomy and Scientific
- Industrial Thermal Imaging
- Moisture Mapping

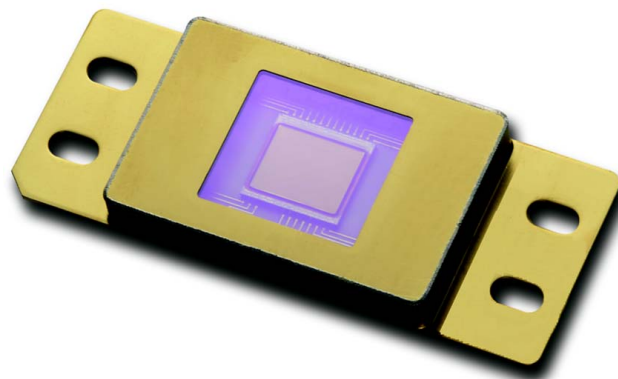

### GENERAL DESCRIPTIONS

PARAMETER	VALUE
Sensor Technology	Standard InGaAs/InP
Spectral Range	0.9 $\mu\text{m}$ -1.7 $\mu\text{m}$
Image Format	320(H)x256(V)
Pixel Pitch	30 $\mu\text{m}$ x30 $\mu\text{m}$ (>99% Fill Factor)
Image Size	9.6mm(H)x7.68mm(V)
Package Type	28-pin Metal DIP Package
Weight	25.6g(TBR)



## FPA CHARACTERISTICS (T<sub>a</sub>=298k)

PARAMETER	TYPICAL	CONDITIONS
Dark Current	≤ 0.4 pA	Pixel bias =0.1 volt
Quantum Efficiency	≥ 70%	λ=1.0um-1.6um
Fill Factor	> 99%	
Detectivity	≥ 5x10 <sup>12</sup> Jones	T <sub>int</sub> =16ms, Low Gain, λ=1.55um
Response Nonuniformity	≤ 10%	Under 50% Saturation
Nonlinearity (Max. Deviation)	≤ 2%	Over 10%-90% Full Well Capacity
Max. Pixel Rate	10MHz	
Gain	High: 13.3 uV/e <sup>-</sup> Low: 0.7 uV/e <sup>-</sup>	
Full Well	High: 170K e <sup>-</sup> Low: 3.5M e <sup>-</sup>	
Pixel Operability*	> 99%(Minimum)	Dark Current ≤20% Full Well Response Nonuniformity ≤ 20%

\* Pixel Operability is defined within the center 318x254 regions

## ABSOLUTE MAXIMUM RATINGS

PARAMETER	UNIT	MIN	MAX
Operation Temperature*	°C	-20	85
Storage Temperature*	°C	-40	85
Power Consumption	mW	---	175**

\* Denotes environment temperature, not chip temperature

\*\* Without driving the cooler



## PACKAGE OUTLINE

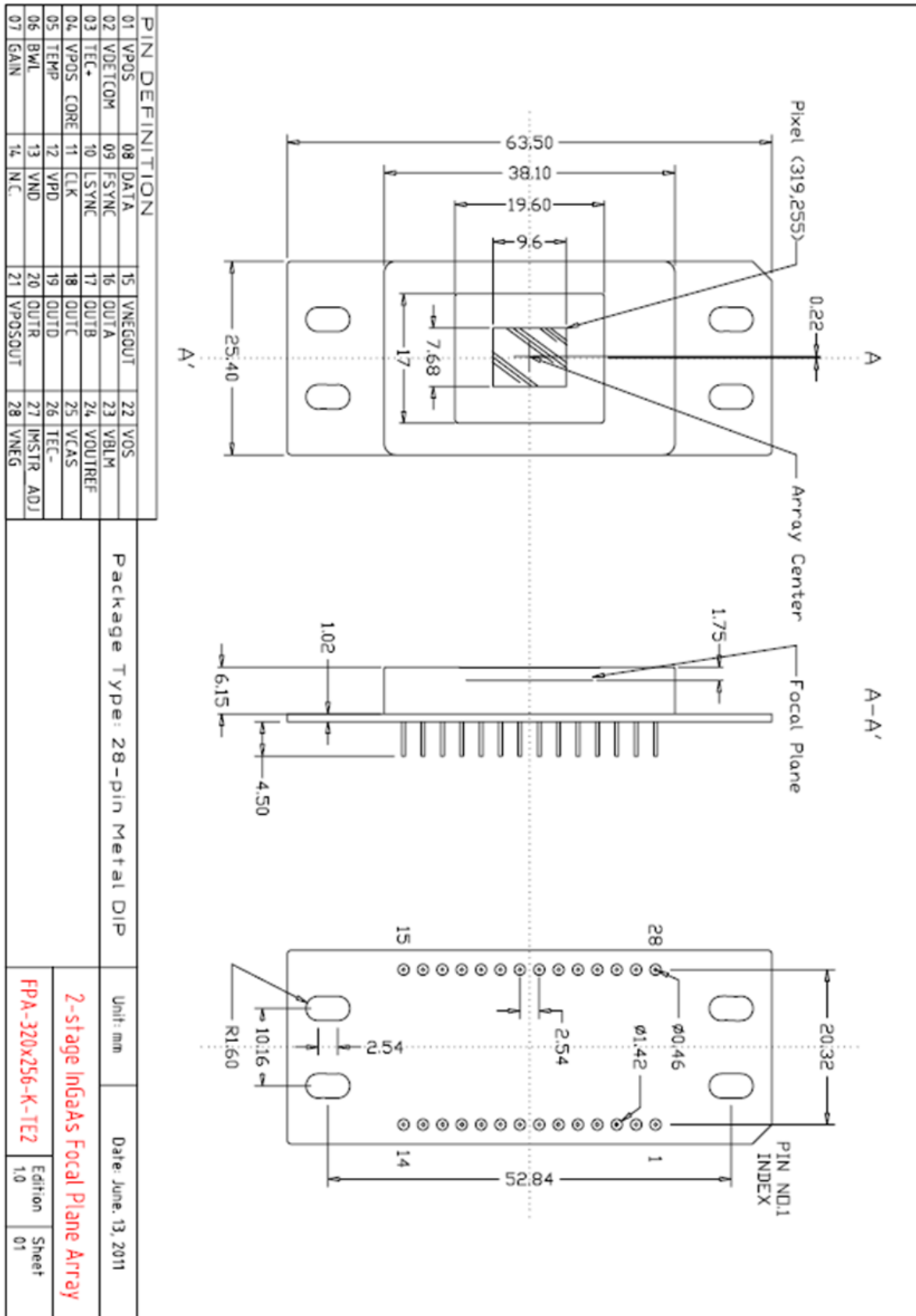

Note : ID number of the imager is printed on the flank of the package



## OPERATING CONDITIONS

### Bias Input

Pin #	Bias	Voltage	Current	Remark
12	VPD	5.5V	<1mA	Logic positive supply
13	VND	0V	<1mA	Logic negative supply
21	VPOSOUT	5.5V	<25mA	Output stage analog supply
15	VNEGOUT	0V	<25mA	Output stage analog ground
1	VPOS	5.5V	<5mA	Positive analog supply
28	VNEG	0V	<15mA	Negative analog supply and substrate
4	VPOS_CORE	5.5V	<15mA	CTIA amplifier positive supply
2	VDETCOM	4.7V - 5.5V	<5mA	Detector common voltage Detector bias = VDETCOM-4.7*

\* VDETCOM lower than 4.7V will forward bias the sensor at 298K, the zero bias voltage is device and temperature dependent.

### Digital Pattern Input

Pin #	Clocks	Levels	Rise/Fall	Remark
11	CLK	0 V - 5.5 V	< 10 ns	Master clock - Max. Freq. = 5 MHz
9	FSYNC	0 V - 5.5 V	< 10 ns	Frame sync - controls frame start and integration time
10	LSYNC	0 V - 5.5 V	< 10 ns	Line sync - controls line readout timing
8	DATA	0 V - 5.5 V	< 10 ns	Data code input - programs device function registers in Control Mode Left open in Default Mode

Clocks	Synchronization
FSYNC	Rising and falling when CLK is rising
LSYNC	Rising and falling when CLK is falling
DATA	Rising and falling when CLK is rising



## Video Output

Pin #	Outputs	Levels	Settle	Remark
16	OUTA	1.3 V to 4.2 V	< 50 ns to 0.1 %	Output A used in single output mode
17	OUTB	1.3 V to 4.2 V	< 50 ns to 0.1 %	Output A and B used in two output mode
18	OUTC	1.3 V to 4.2 V	< 50 ns to 0.1 %	Output A, B, C, and D used in four output mode
19	OUTD	1.3 V to 4.2 V	< 50 ns to 0.1 %	Output A, B, C, and D used in four output mode
20	OUTR	3V	-	Reference for common mode output

## Gain & Bandwidth Selection in Default Mode

Pin #	Functions	Low	High	Remark
7	GAIN	0 V C = 10 fF	5.5 V C = 210 fF	Selects unit cell integration capacitor Left open in Control Mode
6	BWL	0 V Low BW	5.5 V High BW	Selects bandwidth limiting capacitor in unit cell - Left open in Control Mode

## Advanced Functions

Pin #	Functions	Voltages	Remark
25	VCAS*	3.75 V	CTIA amplifier cascode FET bias
24	VOUTREF*	3 V	Output reference level during blanking period
23	VBLM*	2 V	Detector bloom control
27	IMSTR_ADJ**	0 V - 5.5 V	Adjusts analog master bias current
22	VOS	0 V - 5.5 V	Variable Offset/Skimming Control Voltage
5	TEMP***	0 V - 5.5 V	On chip temperature monitor ~0.74 V at 300 K, <b>Slope= -14.8 mV / 10K in 50-300 K</b>

\* Internally generated after bias input, but can be overridden.

\*\* Also addressable through control register (DATA).

\*\*\* The intersection voltage at 300K varies among sensors, but the slope is unchanged.



THERMOELECTRIC COOLER DATA (Without thermal loading)

$\Delta T_{\max}$	$I_{\max}$	$V_{\max}$
91 °C	2.4 A	11.7 V

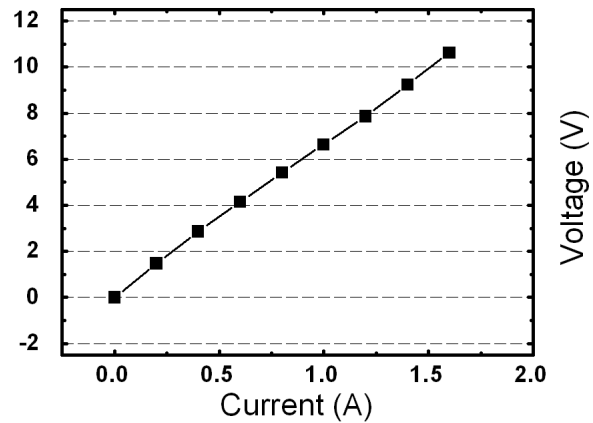
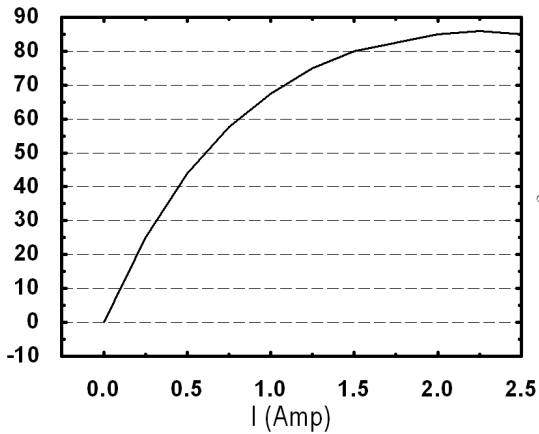

Cooling Performance with sensor loading and operating

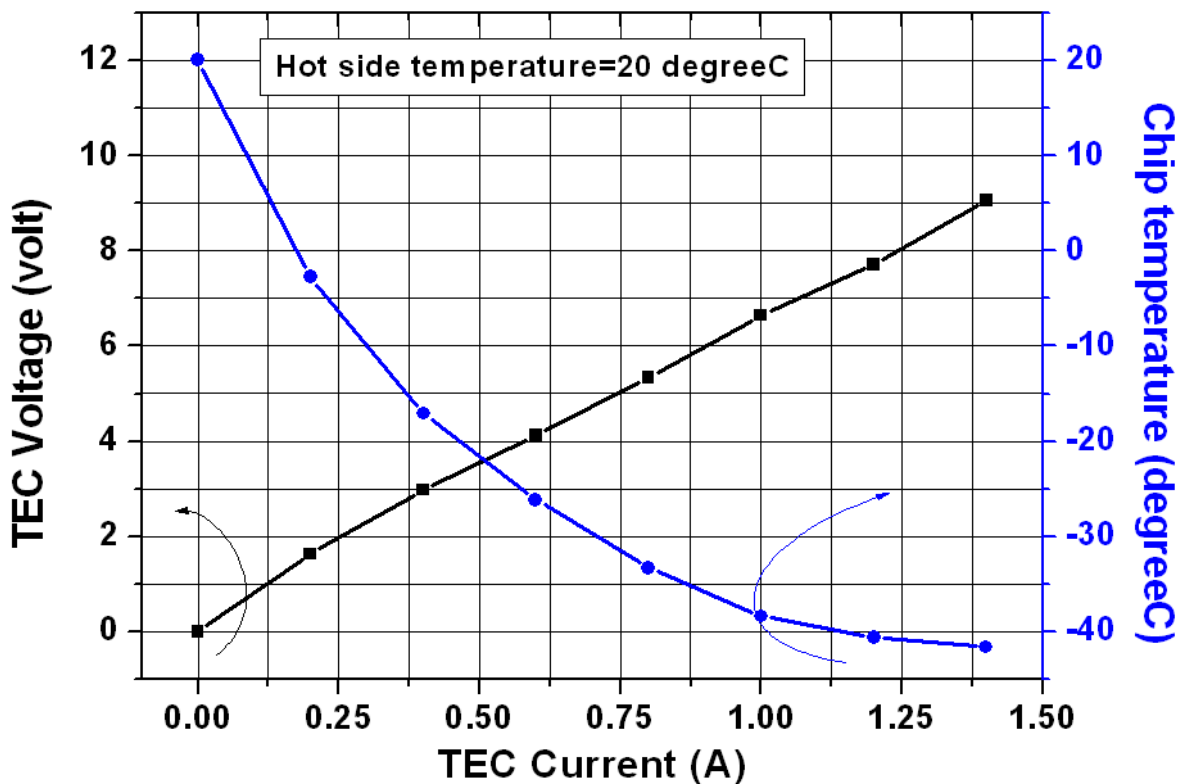



## EXAMPLE CURVES

Statistical Histogram of Dark Current

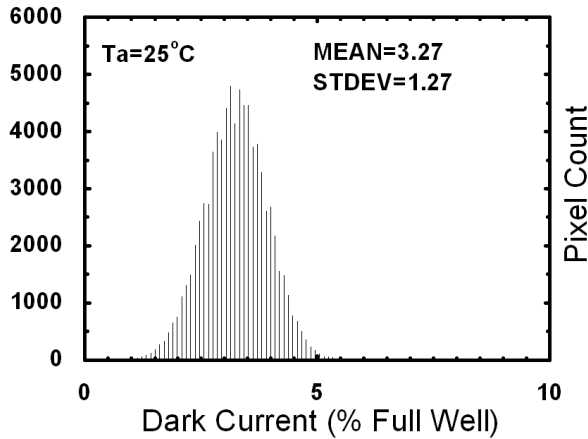

Test Conditions:	
Illumination	Dark
Wavelength	---
Gain	Low
Integration Time	16ms
Remark	Effective Screen

Statistical Histogram of Quantum Efficiency

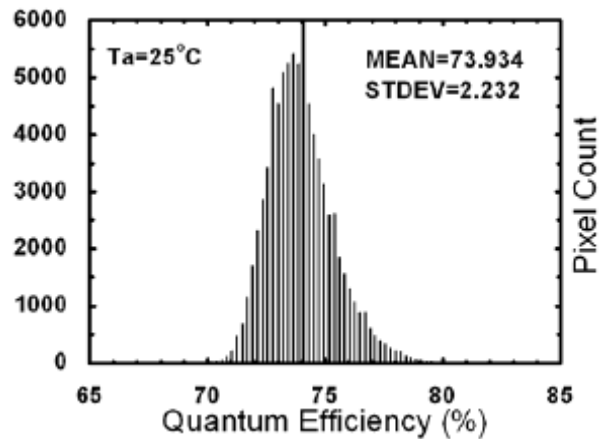

Test Conditions:	
Illumination	Nonuniformity $\leq\pm 0.15\%$
Wavelength	1310nm
Gain	Low
Integration Time	5msec, 50% saturation
Remark	Effective Screen

Quantum Efficiency Spectrum

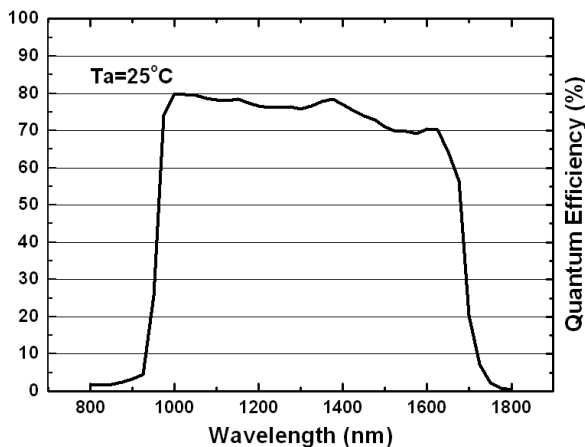

Test Conditions:	
Illumination	Nonuniformity $\leq\pm 0.15\%$
Wavelength	Broadband
Gain	Low
Integration Time	5ms, 50% saturation
Remark	Effective Screen Array Average

Linearity

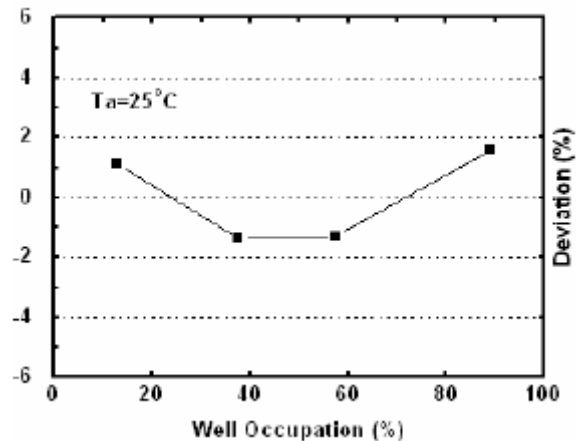

Test Conditions:	
Illumination	Nonuniformity $\leq\pm 0.15\%$
Wavelength	1310nm
Gain	Low
Integration Time	1ms, 3ms, 5ms, 8ms
Remark	Effective Screen Array Average



## TIMING CHART FOR DEFAULT MODE OPERATION

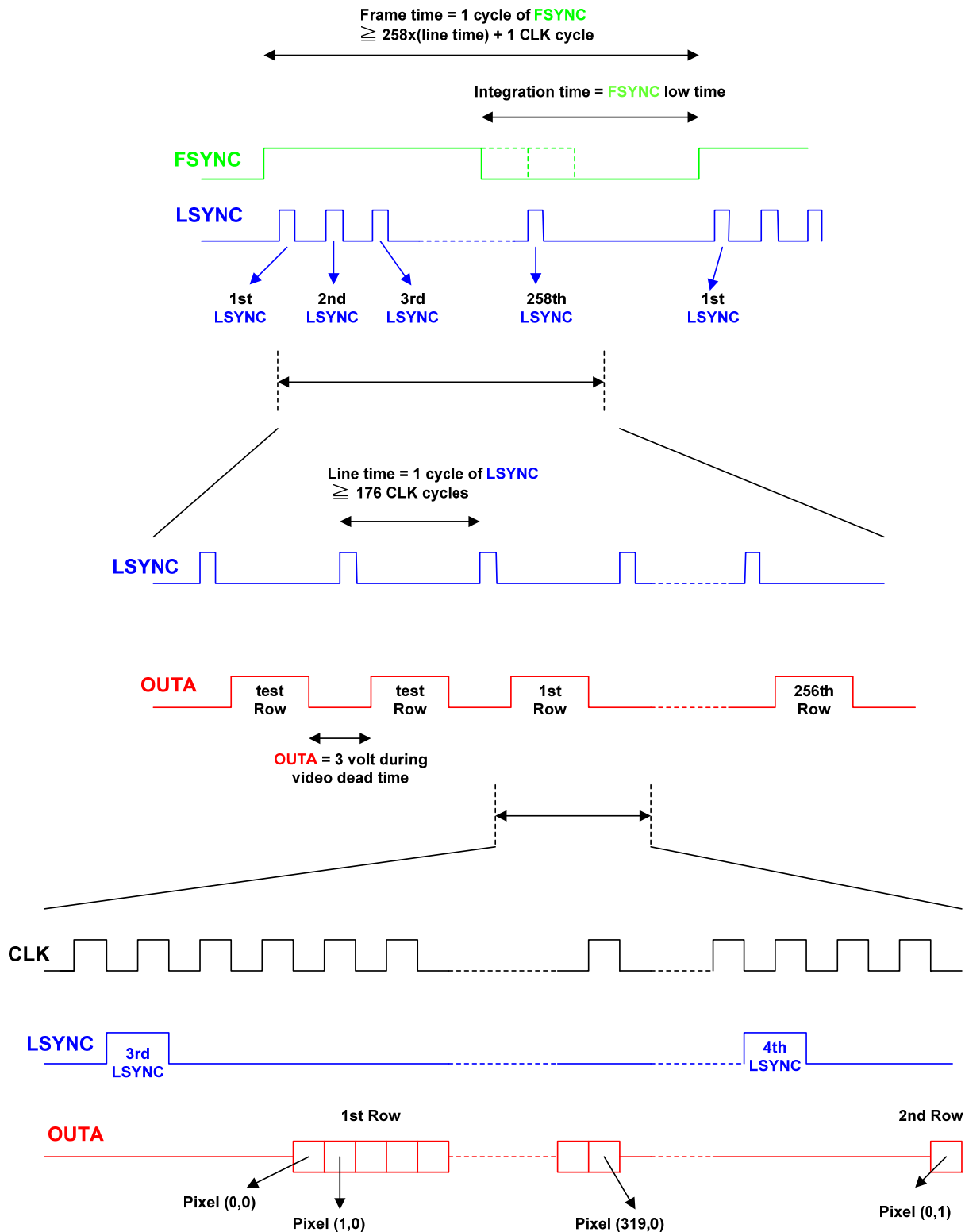



## OUTA waveform under dark

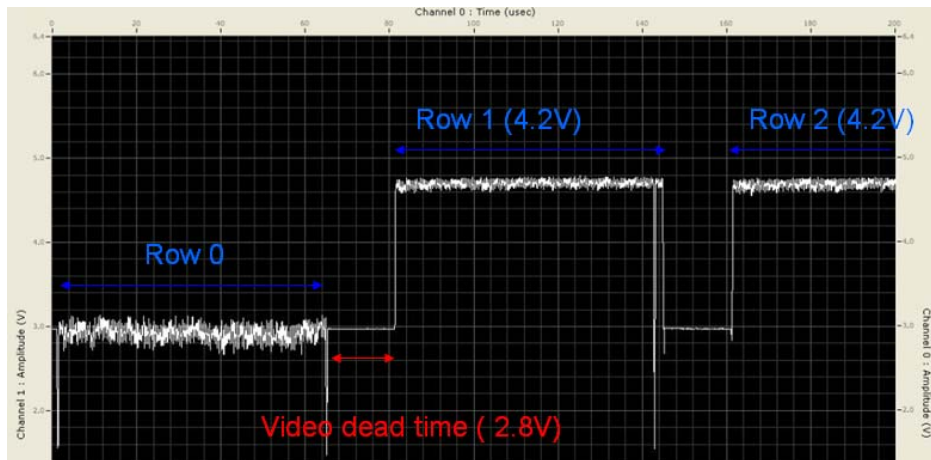

## OUTA waveform under saturation

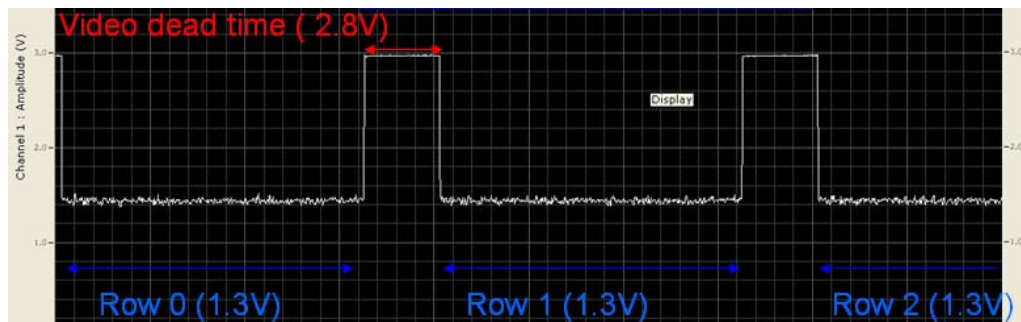

## OUTA waveform under half saturation

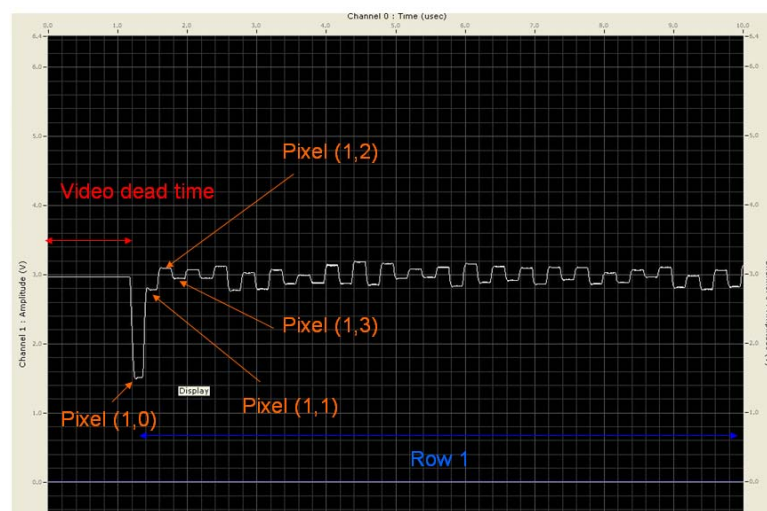

Copyright © 2011 ANDANTA GmbH. The information in this document is subject to change without notice. All rights reserved.