



Outline

See the difference with true day/night!

Lumenera's Le075 series of network cameras are designed for general security applications, providing high quality, progressive scan images.

Streaming full 640x480 resolution at up to 60 frames/sec, these cameras deliver outstanding picture quality and performance. Adjustable JPEG and MJPEG compressed still-images or live streaming video, are provided across a standard 10/100BaseT network interface.

Lumenera has simplified IP camera installation with a straightforward plug-and-play process. Intuitive user interface viewed with most browsers provides standard camera control.

The I/O connector provides an interface to an external alarm sensor or control of peripheral equipment such as; IR lighting, DC iris and PTZ. Alarm notification provides the date, time and camera IP address.

Programmable day/night settings automatically switch to enhanced low-light mode. Optional – True day/night module provides automatic sliding IR cut filter. When integrated with NIR illuminators, provides outstanding nighttime performance.

The user defined motion detection parameters across multiple zones provide more accurate triggering of alarms, while programmable privacy zones ensure compatibility with all regulations.

On-board memory buffers supply still images that precede and follow alarm events. Transfer of images via email, FTP, RTP or HTTP.

Model Le075 is very compact, contained in an all-metal housing and can be mounted stand-alone or by means of standard environmental enclosures. Call with your enclosure requirements today.

Product Features

- Easy installation and set-up
- 480 lines of resolution, color or monochrome, progressive scan, 640x480 pixel sensor
- Up to 60 fps at full 640x480 (VGA) resolution
- Feature rich camera functions:
 - Auto White Balance & Auto Exposure
 - Day/Night Mode
 - Configurable Compression Ratio
 - Multiple motion detection zones
- I/O control of alarms, DC iris, PTZ, lighting or other peripherals
- Optional true day/night functionality
- Image transfer via HTTP, FTP, RTP, or Email
- Camera Control via HTTP, XML-RPC, Telnet or Microsoft COM
- Security / Password Protection
- FCC Class B, CE Certified
- CS lens mount provided standard, C-mount adapter available
- Compatible with most Operating Systems (Windows™ 98 SE, Windows Me, Windows 2K, Windows NT and Windows XP, as well as Linux and Mac)
- Full 1 year warranty

Image Sensor	1/3" format, color or mono, 5.79mm x 4.89mm array
Effective Pixels	640x480, 7.4µm square pixels
Frame Rate	60 fps at 640x480, 100+ fps at 320x240 (binned)
Dynamic Range	60dB
Sensitivity	0.1 lux at F 1.0
Auto Exposure	Automatic / Manual
White Balance	Automatic / Manual
Dimensions (W x H x D)	1.9" x 2.25" x 5.0" (not including lens)
Mass	~300g
Power Requirement	9-24V AC or DC
Power Consumption	<4 Watts
Operating Temperature	-10° C to +50° C (environmental enclosure will provide extended temperatures with fan / heater)
Operating Humidity	5%-95%, Non-condensing
Interface Connector	RJ45 twisted pair cable, 10/100baseT Ethernet
Lens Mount	Adjustable CS-Mount (lens not included)
Image Buffer	48 MB (up to 2000 full res images)

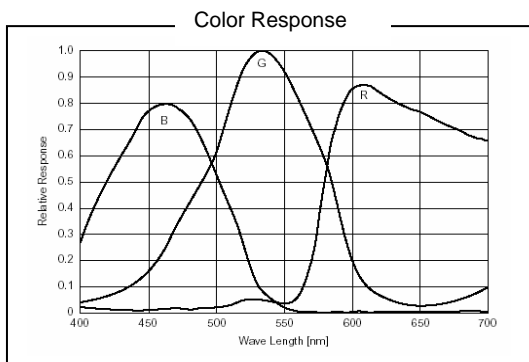

Recommended PC Specifications

O/S: Windows 2000 (SP 3), or XP (SP 1)
 CPU: 2.8GHz or above Pentium computer
 (required for full frame rate preview)

600Mhz or above Pentium compatible
 computer (for basic functionality)

Network: 100 Mbps Ethernet LAN
 Browser: Internet Explorer v6.0

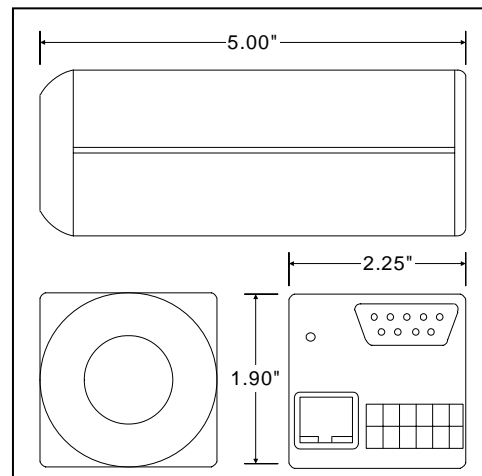

Ordering Information

Le075C	- VGA Color Camera
Le075M	- VGA Monochrome Camera
Le075C-DN	- VGA Color Camera with optional Day/Night module