

1.3 Megapixel USB 2.0 Camera**Outline**

Lumenera Lw110 and Lw115 megapixel cameras are designed for use in a wide variety of industrial applications requiring high resolution and modest cost.

With 1280x1024 resolution and on-board processing these cameras deliver outstanding image quality and value. Uncompressed images in live streaming video and still image capture are provided across a USB 2.0 digital interface. No framegrabber is required. Advanced camera control is available through a complete Software Developer's Kit (SDK), with sample code available to quickly integrate camera functions into OEM applications.

Hardware and software based synchronization trigger is provided standard. Enclosed (Lw115) board-level (Lw110) and custom form factors available.

All Lumenera products are supported by an experienced team of software developers and application engineers. We understand your imaging needs and are here to help you with your integration and development.

Performance Features

- Lower fixed pattern noise
- GPI/O for control of peripherals and synchronization of lighting (4in/4out) a standard feature
- Stable, reliable camera drivers for running multiple cameras on a PC or other USB devices
- Color, progressive scan, 1.3 megapixel image sensor
- High-speed USB 2.0 (480Mbits/sec)
- 30 fps at full 1280x1024 resolution
60 fps at 640x480 resolution
- Auto white balance, auto exposure
- Snapshot mode for use with strobe
- RGB Bayer video output
- Select 8 or 12-bit pixel data
- Simplified cabling - video, power and full camera control over a single USB cable
- Adjustable C-Mount provided
- DirectShow compatible
- USB cameras are software compatible with Windows™ XP, Windows Vista and Windows 7, 32 and 64-bit operating systems
- Complete SDK available
- Full one (1) year warranty

Specifications

Lw110/Lw115

Image Sensor	1/3" format, color, 4.65mm x 3.72mm array
Effective Pixels	1280 x 1024, 3.63µm square pixels
Frame Rate	30 fps at 1280x1024, 60 fps at 640x480
Sensitivity	High
Dynamic Range	60dB
Auto Exposure	Automatic / Manual
White Balance	Automatic / Manual
Dimensions (W x H x D)	2.00 x 2.50 x 1.63 inches (board level) 2.25 x 3.85 x 1.56 inches (enclosed)
Mass	~150g / 300g
Power Requirement	USB bus power, or external 5VDC, 500mA
Power Consumption	~2.5 Watts
Operating Temperature	0°C to +50°C
Operating Humidity	5% - 95%, Non-condensing
Interface Connector	Standard USB
Lens Mount (Lens not included)	Adjustable C-Mount (CS-Mount option)
Certification	FCC Class B, CE Ready

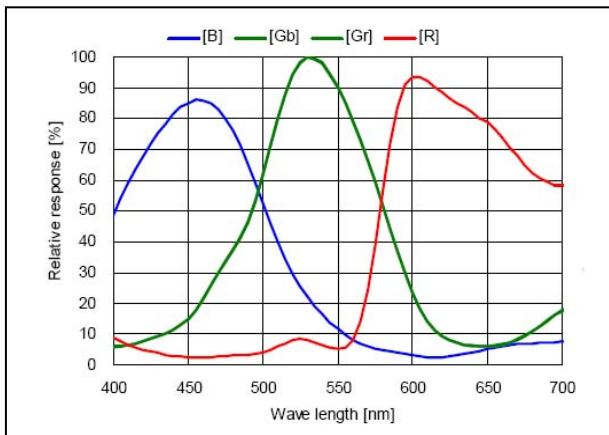

Full customization available to meet your exact needs!

Available Options:

- Without Standard IR-Cut Filter
- Without Glass in Lens Mount
- Without Lens Mount
- Board Level
- Adjustable CS-Mount

Contact us for more specific details.

Ordering Information

- Lw110C - 1.3 Megapixel Color Camera Module
- Lw115C - 1.3 Megapixel Enclosed Color Camera
- LuSDK - Software Developer's Kit

OEM Board-Level Camera

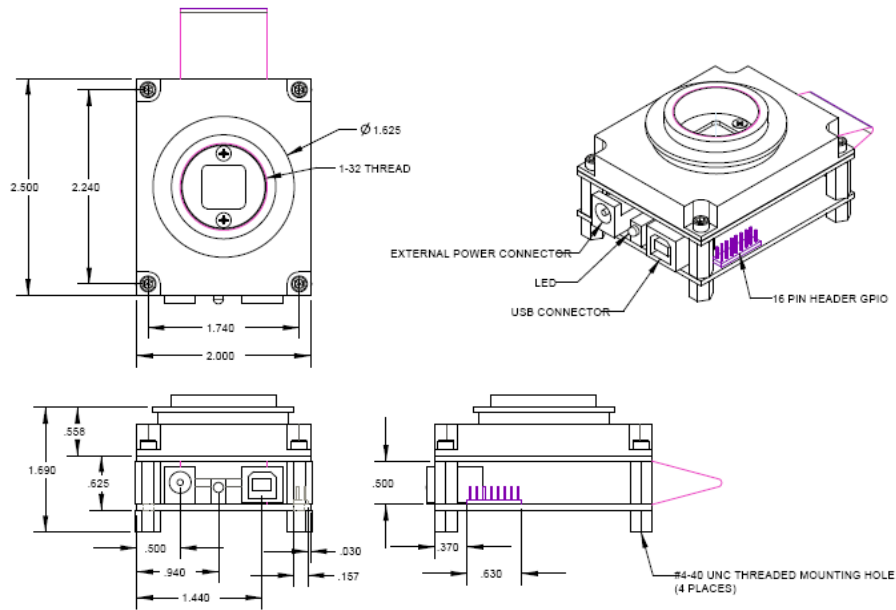

Lw BOARD LEVEL CAMERA WITH ADJUSTABLE CCD MOUNT

Enclosed Camera *

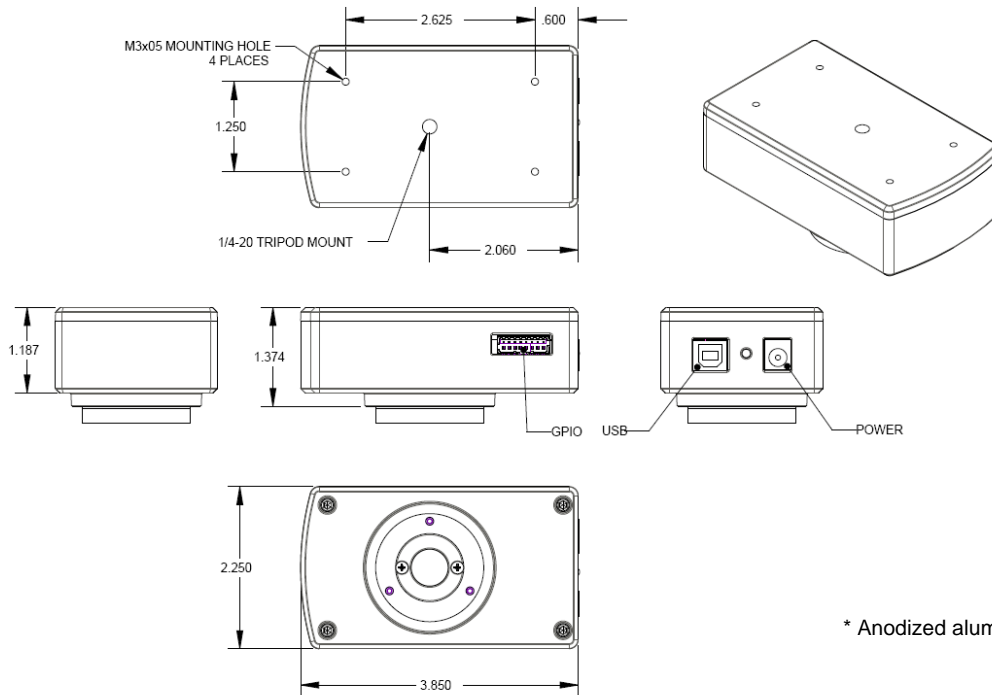

* Anodized aluminum, std color - black

INDUSTRIAL DIE CAST CAMERAS