

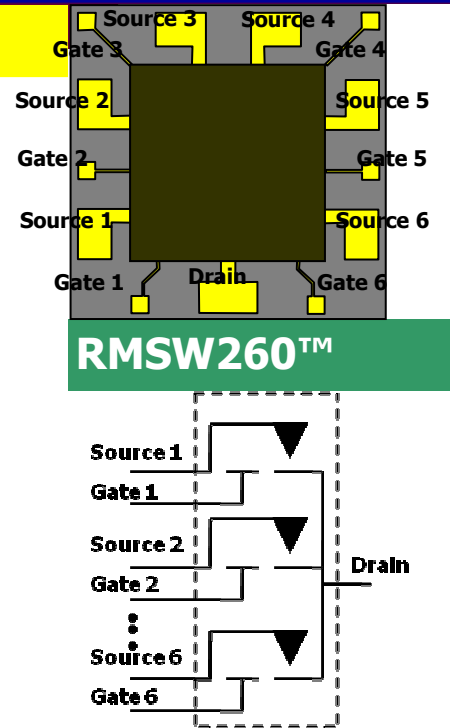

SP6T RF-MEMS Switch DC to 20 GHz



Features

- High Isolation (>22 dB typical @ 18 GHz)
- Low Insertion Loss (<0.5 dB @ 10 GHz, <0.8 dB @ 18 GHz)
- Near Zero Harmonic Distortion
- No Quiescent Power Dissipation
- Long Life (typical lifetime >100 billion cycles @ 27 dBm, >1 billion cycles @ 30 dBm)
- Hermetically sealed die designed for die-attach and wire-bond to board. Please contact us for other packaging options.

Description

The RMSW260™ is a Single Pole Six Throw (SP6T) Reflective RF Switch utilizing Radant's breakthrough MEMS technology that delivers high linearity, high isolation and low insertion loss in a chip-scale package configuration.

This device is ideally suited for use in many applications such as RF and microwave multi-throw switching, radar beam steering antennas, phase shifters, RF test instrumentation, ATE, cellular, and broadband wireless access.

Typical Device Specifications

Insertion Loss DC 2 GHz 10 GHz 18 GHz	< 4 Ω < 0.3 dB < 0.5 dB < 0.8 dB	Lifecycle Cold-switched, 27 dBm Cold-switched, 30 dBm Cold-switched, 33 dBm Hot-switched, -20 dBm Hot-switched, -10 dBm Hot-switched, 20 dBm	> 10 ¹¹ cycles > 10 ⁹ cycles > 10 ³ cycles > 10 ¹¹ cycles > 10 ⁹ cycles > 10 ³ cycles
Isolation DC 2 GHz 10 GHz 18 GHz	> 1 GΩ > 36 dB > 25 dB > 22 dB	Control Gate-Source Voltage (on) Gate-Source Voltage (off) Control Power, steady-state Control Power, 1 KHz cycle rate	+/- 100 V 0 V < 1 nW < 2 μW
Return Loss 2 GHz 10 GHz 18 GHz	< -35 dB < -22 dB < -18 dB	Switching speed On Off	< 10 μs < 2 μs
Input IP3 (Two-tone inputs 900 MHz and 901 MHz up to +5 dBm)	> 65 dBm	Operating temperature Maximum Minimum	85 °C -40 °C
		Storage temperature Maximum Minimum	150 °C -55 °C

Notes:

1. All RF measurements were made in a 50 Ω system.
2. Measurements include bond-wires from die to test-board.

- Phone: 978-562-3866
- Fax: 978-562-6277
- Email: sales@radantmems.com
Visit www.radantmems.com

Typical RF Performance

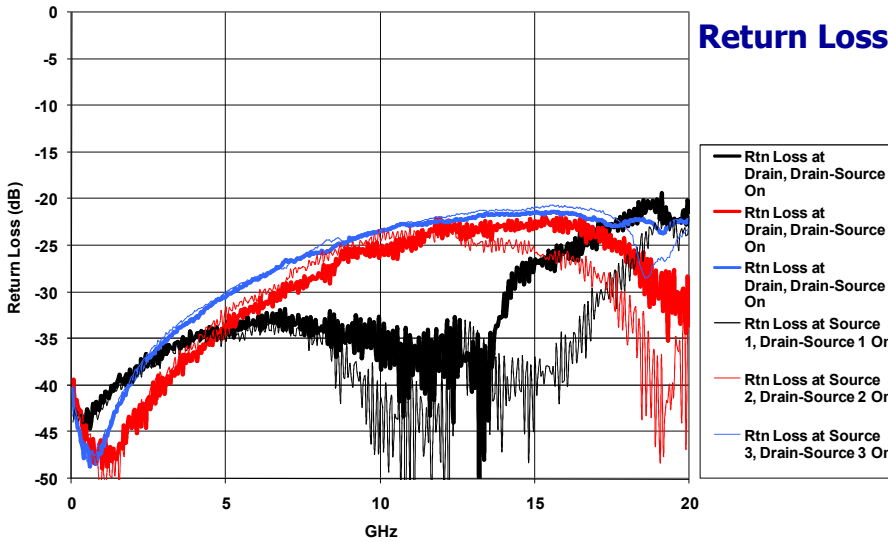
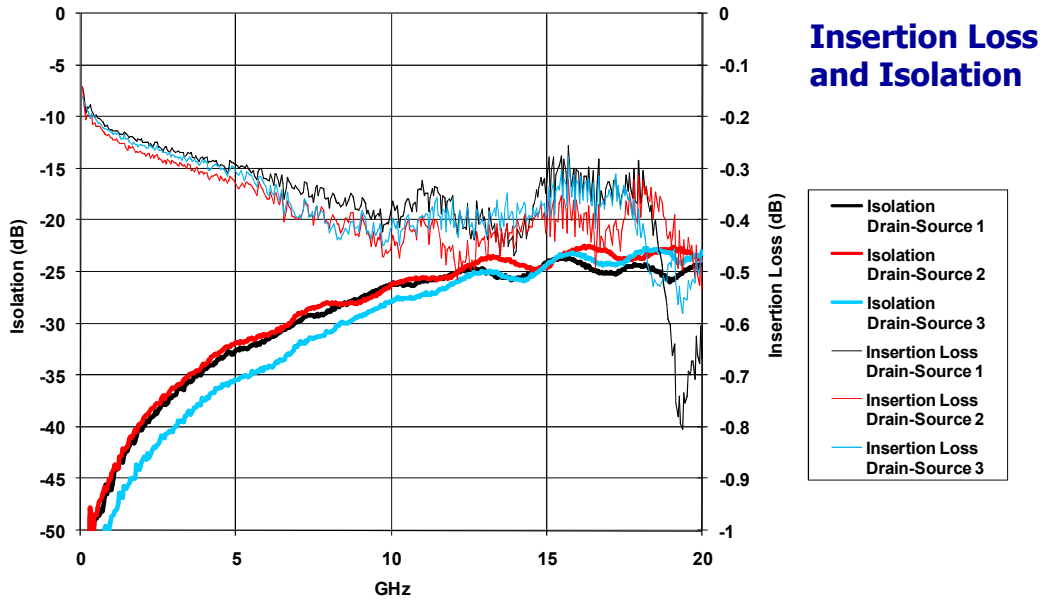

* Measurement results include bond wires

Absolute Maximum Ratings

Maximum Temperature (10 seconds)	290 °C
Maximum Temperature (120 seconds)	250 °C
Maximum Voltage, Gate-Source	+/- 130 V
Maximum Voltage, Drain-Source	+/- 100 V

- Phone: 978-562-3866
- Fax: 978-562-6277
- Email: sales@radantmems.com
- Visit www.radantmems.com

Recommended Application

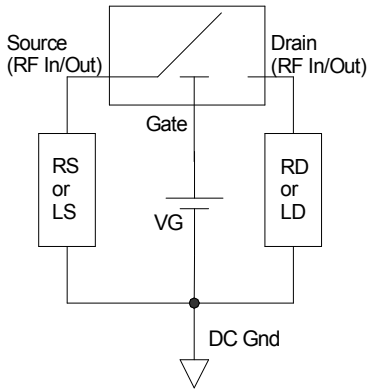

1. Figure shows one of the six legs of the SP6T switch. The Drain terminal is common to all six legs.
2. A resistor RS (40 KΩ-100 KΩ) or inductor LS should be used to provide a path to DC Ground from each Source. Similarly, a resistor RD (40 KΩ-100 KΩ) or inductor LD should be used to provide a path to DC Ground from the common Drain.
3. VG may be of either polarity.
4. VG rise-time should be at least 10 μs for optimal lifetime.
5. Please refer to "Application Note for Test and Handling of SPST RF-MEMS Switches" for more information. Contact us for driver solutions.

Nominal Device Dimensions

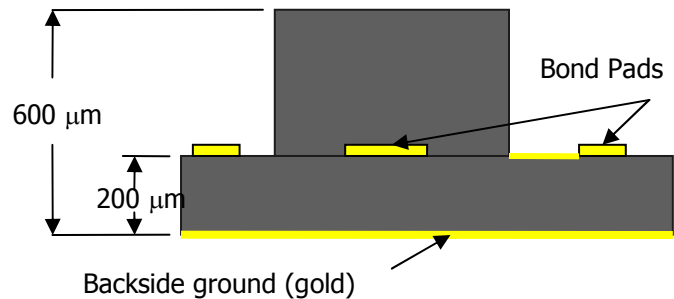
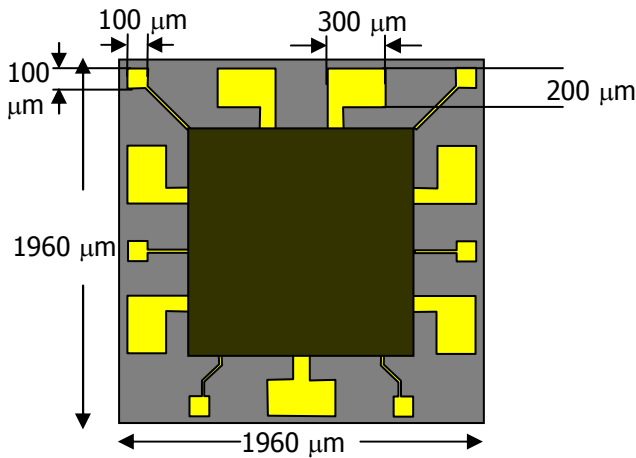

Please contact us for a footprint in .gds or .dxf format.

Static sensitivity

This device has an ESD (HBM) sensitivity of 100 V. Use proper ESD precautions when handling. Please refer to "Application Note for Test and Handling of SPST RF-MEMS Switches" for more information.

Die Assembly

The gold backside-metallization on the die is designed to be mounted with electrically conductive silver epoxy, or with a lower temperature solder which does not consume gold. Bond pads on the die are made of gold. Ball-bonds should be utilized to attach gold or Aluminum 1 mil wires. Please refer to "Application Note for Test and Handling of SPST RF-MEMS Switches" for more information.

- Phone: 978-562-3866
- Fax: 978-562-6277
- Email: sales@radantmems.com
Visit www.radantmems.com